

PARALLEL ARM INSTALLATION CLOSER MOUNTED ON DOOR ON PUSH SIDE

This drawing shown is **RIGHT HAND DOOR**, for LEFT HAND DOOR install opposite

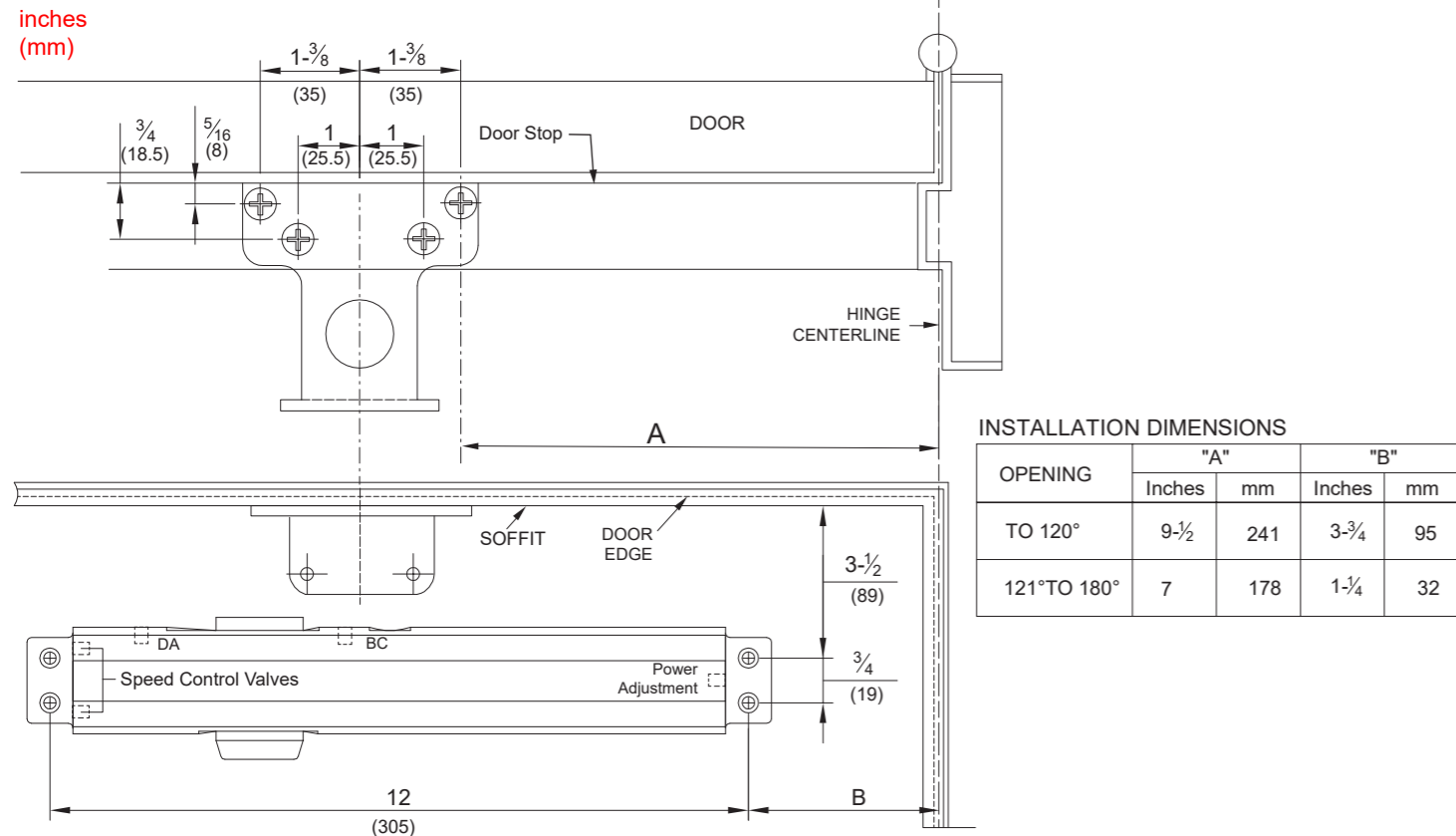

DOOR CLOSER INSTALLATION

1. Refer to installation instructions supplied with door closer.
2. Adjust spring power to match door size as indicated in chart on page 1.
3. Mount door closer on door using dimensions for the selected door opening angle, with speed control valves facing away from the hinges.
4. Mount parallel arm bracket on frame stop soffit using dimensions for the selected door opening angle.
5. Disconnect main arm from the forearm. Using a wrench on the door closer bottom shaft rotate shaft about 45° towards the hinges and place main arm on door closer top shaft and attach with screw.
6. Attach forearm (friction arm) shoe on the parallel arm bracket with two machine screws. Position hold-open adjusting nut on top for right hand (RH) door or bottom for left hand (LH) doors.
7. Close door, loosen hold-open adjusting nut (turn clockwise), and position main arm parallel to the door surface and adjust length of threaded rod of forearm to connect to the main arm. Secure forearm (friction arm) to main arm with screw.

DOOR CLOSER ADJUSTMENTS

1. Refer to adjustment instructions supplied with door closer and pictorials on page 1.
2. Adjust closing speed and latch speed so that the door closes for a 120° door opening position within 6-7 seconds, evenly divided between sweep speed and latch speed.
3. To adjust the hold-open position, open the door to the desired opening angle and tighten the adjusting nut (turn counterclockwise) on the friction arm. Close and open the door and verify that the hold open works.
4. Adjust backcheck if required.

COVER INSTALLATION

1. Place cover over door closer and attach with supplied screws.
2. Place shaft cover on the exposed door closer shaft.

TDC 85 SERIES DOOR CLOSER WITH FRICTION HOLD OPEN ARM INSTALLATION INSTRUCTIONS

REGULAR MOUNT
(PULL SIDE)

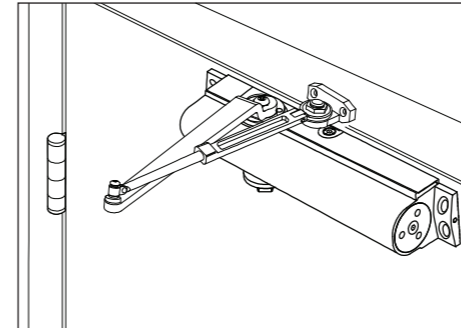

TOP JAMB MOUNT
(PUSH SIDE)

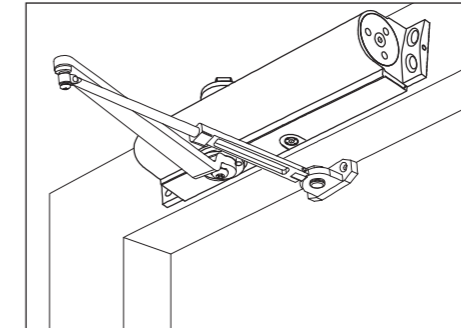

PARALLEL MOUNT
(PUSH SIDE)

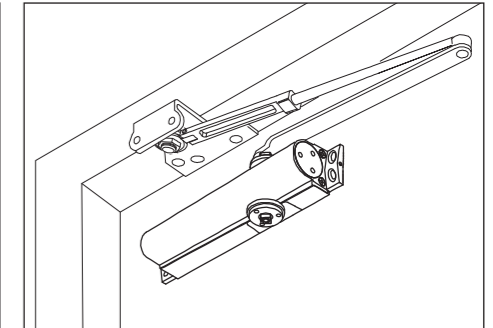

POWER ADJUSTMENT CHART

MAXIMUM DOOR WIDTH		FULL TURNS REQUIRED
EXTERIOR DOORS	INTERIOR DOORS	
—	5lb-f*	5 TURNS CCW
8.5lb-f*	34"(864)	3 TURNS CCW
30"(762)	38"(962)	0 TURNS
36"(914)	48"(1219)	5 TURNS CW
42"(1067)	54"(1372)	10 TURNS CW
48"(1291)	60"(1542)	15 TURNS CW

CCW : Counterclockwise CW: Clockwise
* pound (force)

DOOR HANDING

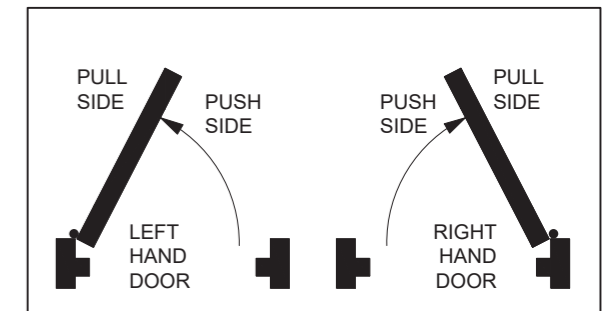

Refer to installation instructions supplied with door closer

Closing / Sweep Speed (S)

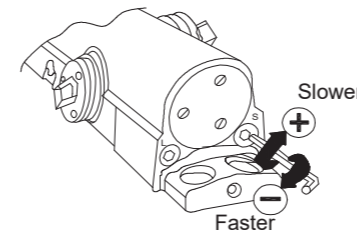

Latch Speed (L)

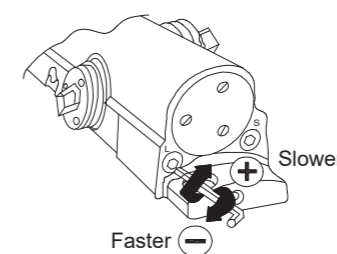

Spring Power Adjustment

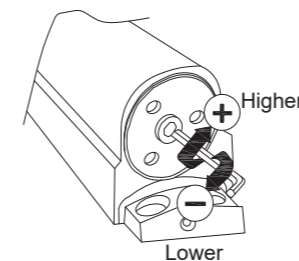

Backcheck (BC)
Delayed Action Control (DA)

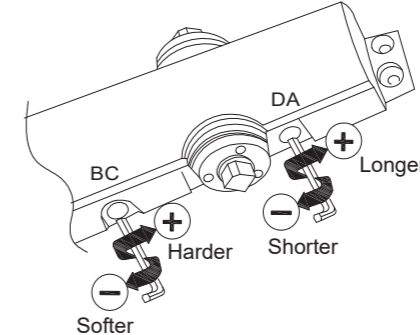

CONTROL RANGE

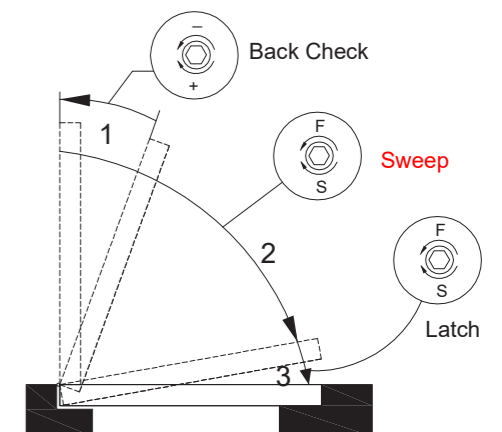

REGULAR ARM INSTALLATION CLOSER MOUNTED ON DOOR ON PULL SIDE

This drawing shown is **LEFT HAND DOOR**, for RIGHT HAND DOOR install opposite

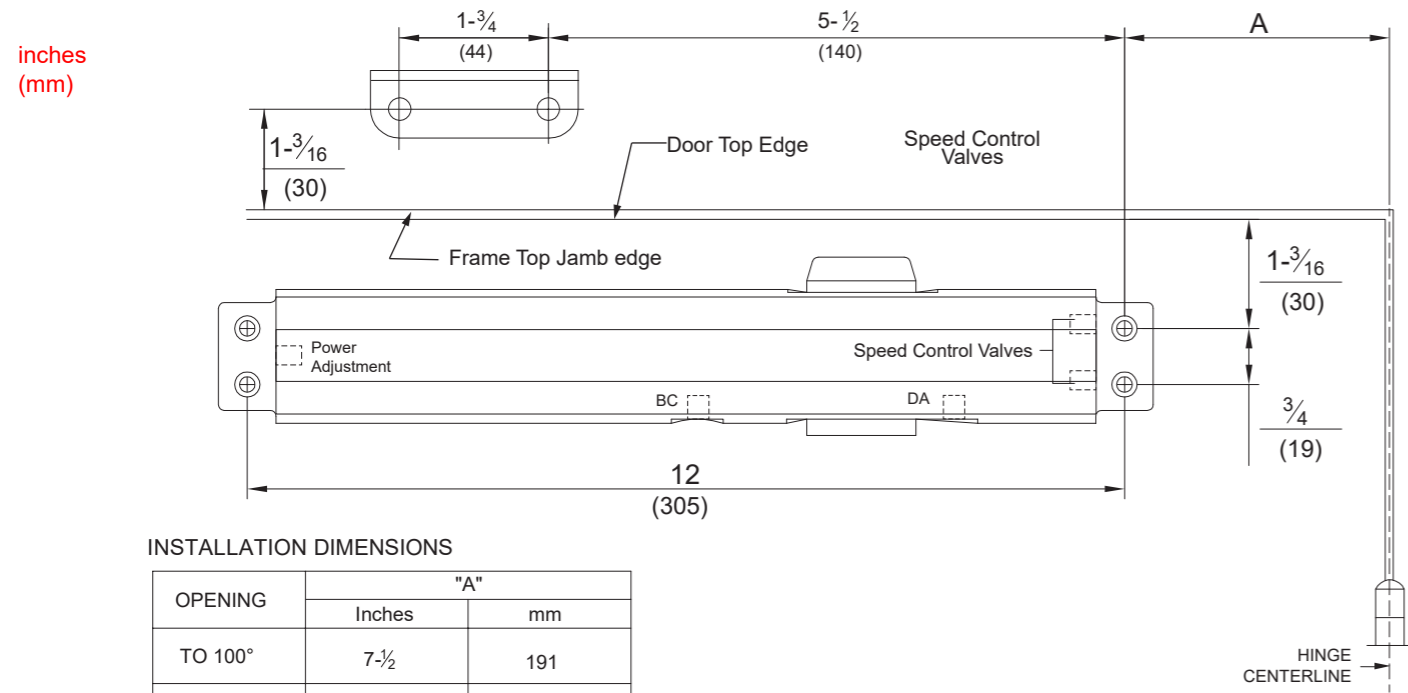

INSTALLATION DIMENSIONS

OPENING	"A"	
	Inches	mm
TO 100°	7-1/2	191
101° TO 130°	6	152
131° TO 180°	4-1/2	114

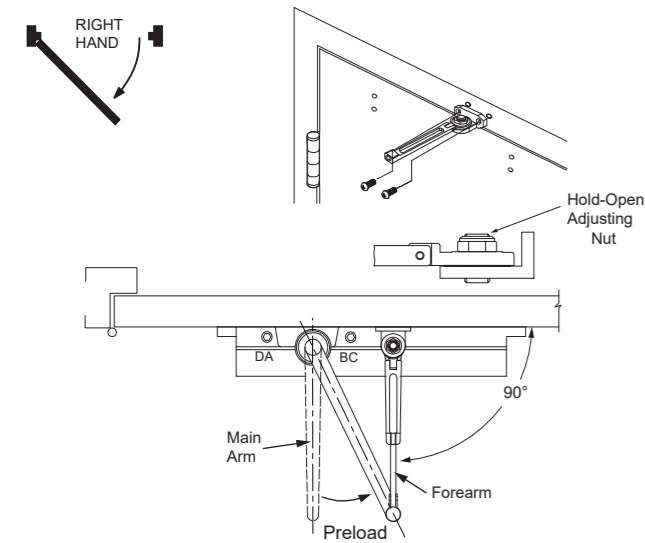

DOOR CLOSER INSTALLATION

1. Refer to installation instructions supplied with door closer.
2. Adjust spring power to match door size as indicated on chart on page 1.
3. Mount door closer on door using dimensions for the selected door opening angle, with speed control valves facing the hinges.
4. Disconnect the forearm from the main arm. Place main arm on door closer top shaft as shown in the illustration and attach with screw.
5. Mount forearm (friction arm) shoe on the door frame using dimensions for the selected door opening angle. Position hold-open adjusting nut on top for right hand (RH) door or bottom for left hand (LH) doors.
6. Close door, loosen hold-open adjusting nut (turn clockwise), position forearm (friction arm) perpendicular to the door surface and adjust its length to connect to the main arm. Secure friction arm to main arm with screw.

DOOR CLOSER ADJUSTMENTS

1. Refer to adjustment instructions supplied with door closer and pictorials on page 1.
2. Adjust closing speed and latch speed so that the door closes within 6-7 seconds, evenly divided between sweep speed and latch speed.
3. To adjust the hold-open position, open the door to the desired opening angle and tighten the adjusting nut (turn counterclockwise) on the friction arm. Close and open the door and verify that the hold open works.
4. Adjust backcheck if required.

COVER INSTALLATION

1. Place cover over door closer and attach with supplied screws.
2. Place shaft cover on the exposed door closer shaft.

TOP JAMB INSTALLATION CLOSER MOUNTED TOP JAMB ON PUSH SIDE OF DOOR.

This drawing shown is **RIGHT HAND DOOR**, for LEFT HAND DOOR install opposite

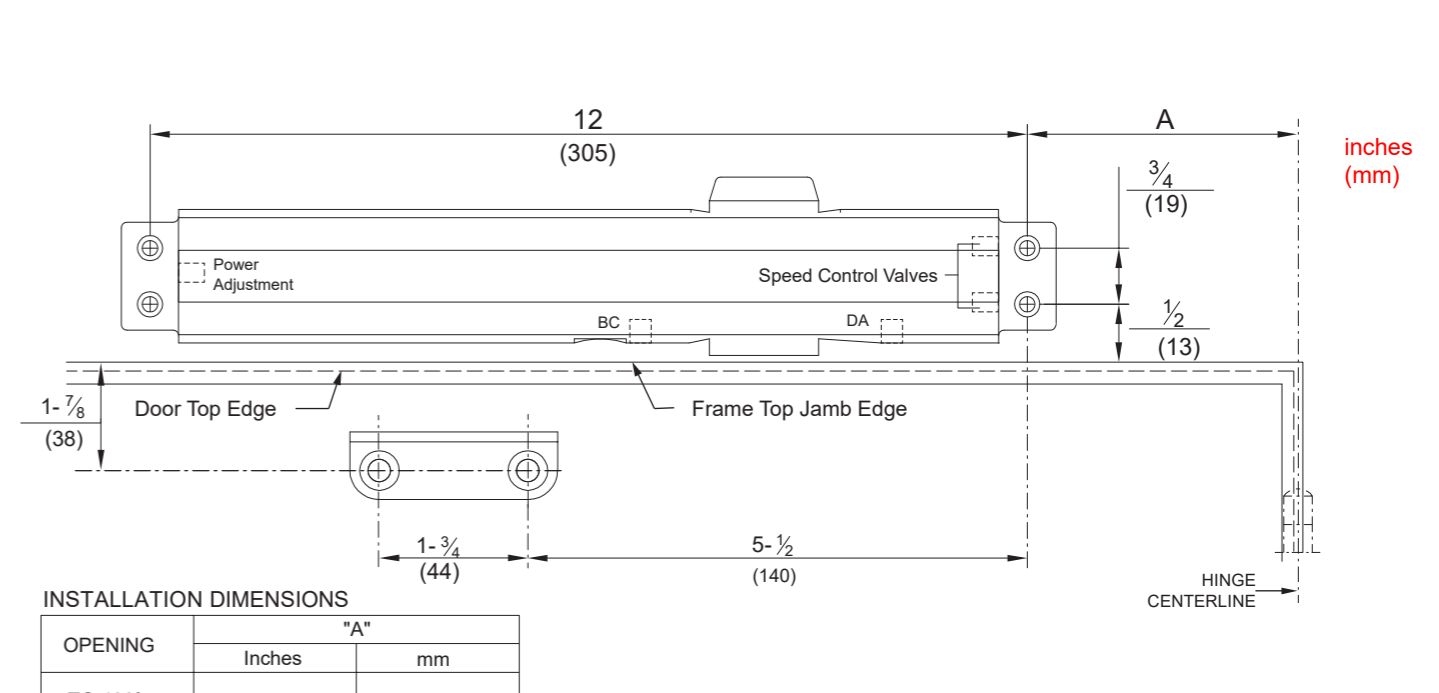

INSTALLATION DIMENSIONS

OPENING	"A"	
	Inches	mm
TO 100°	7-1/2	191
101° TO 130°	6	152
131° TO 180°	4-1/2	114

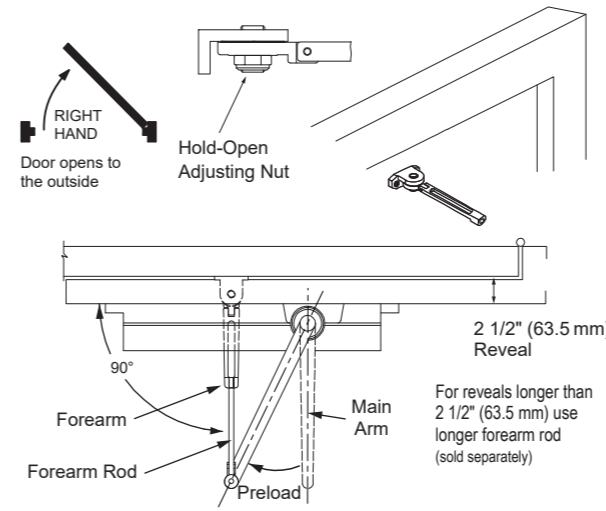

DOOR CLOSER INSTALLATION

1. Refer to installation instructions supplied with door closer.
2. Adjust spring power to match door size as indicated in chart on page 1.
3. Mount door closer on frame top jamb using dimensions for the selected door opening angle, with speed control valves facing the hinges.
4. Disconnect the forearm from the main arm. Place main arm on door closer bottom shaft and attach with screw.
5. Mount forearm (friction hold open arm) shoe on the door using dimensions for the selected door opening angle. Position hold-open adjusting nut on bottom for right hand (RH) door or top for left hand (LH) doors.
6. Close door, loosen hold-open adjusting nut (turn clockwise), position forearm (friction arm) perpendicular to the door surface and adjust its length to connect to the main arm. Secure friction arm to main arm with screw.

DOOR CLOSER ADJUSTMENTS

1. Refer to adjustment instructions supplied with door closer and pictorials on page 1.
2. Adjust closing speed and latch speed so that the door closes within 6-7 seconds, evenly divided between sweep speed and latch speed.
3. To adjust the hold-open position, open the door to the desired opening angle and tighten the adjusting nut (turn counterclockwise) on the friction arm. Close and open the door and verify that the hold open works.
4. Adjust backcheck if required.

COVER INSTALLATION

1. Place cover over door closer and attach with supplied screws.
2. Place shaft cover on the exposed door closer shaft.