

TDC 85 HEDA

Hold Open Extra Heavy Duty Parallel Arm

PUSH SIDE MOUNTING

LEFT HAND DOOR SHOWN

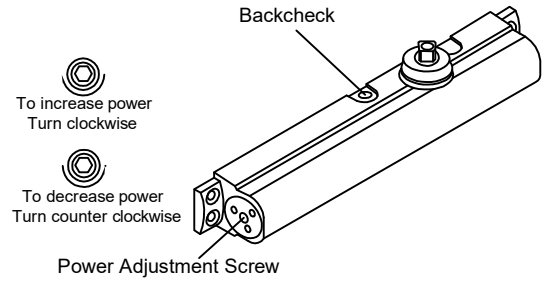
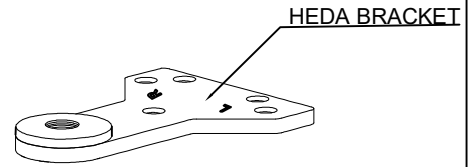
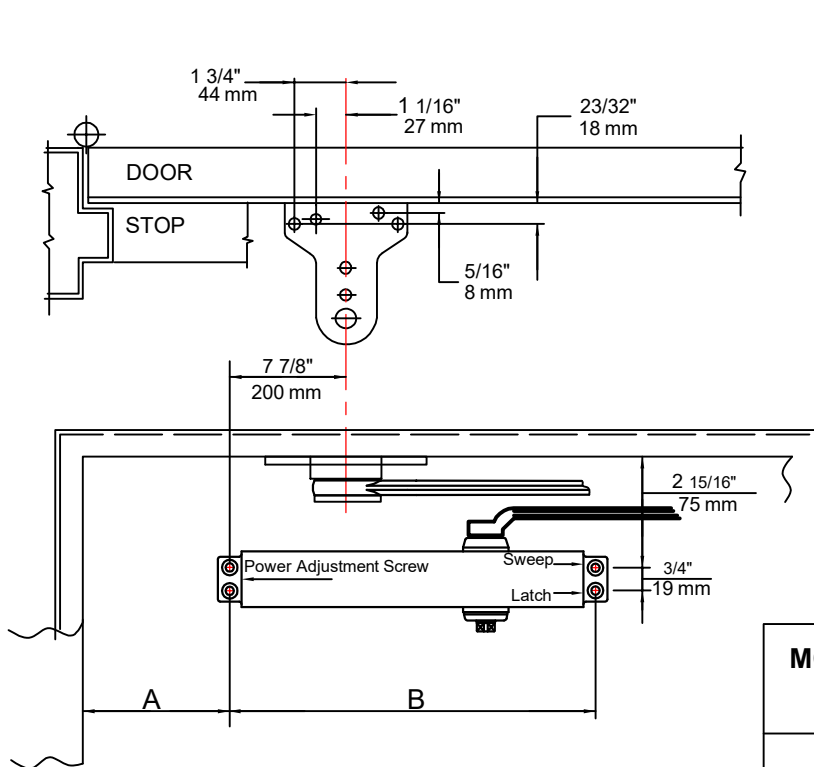

MODEL NO.	OPENING	DIMENSION	
		A	B
TDC 85-HEDA	To 100°	3 1/2" (90 mm)	12" (305 mm)
	101°-150°	1 1/4" (32 mm)	12" (305 mm)

PUSH SIDE MOUNTING

RIGHT HAND DOOR SHOWN

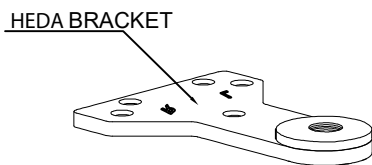

DOOR CLOSER ADJUSTMENT

L:LATCH SPEED VALVE
S:SWEEP SPEED VALVE
D:DELAY SPEED VALVE
B:BACKCHECK VALVE

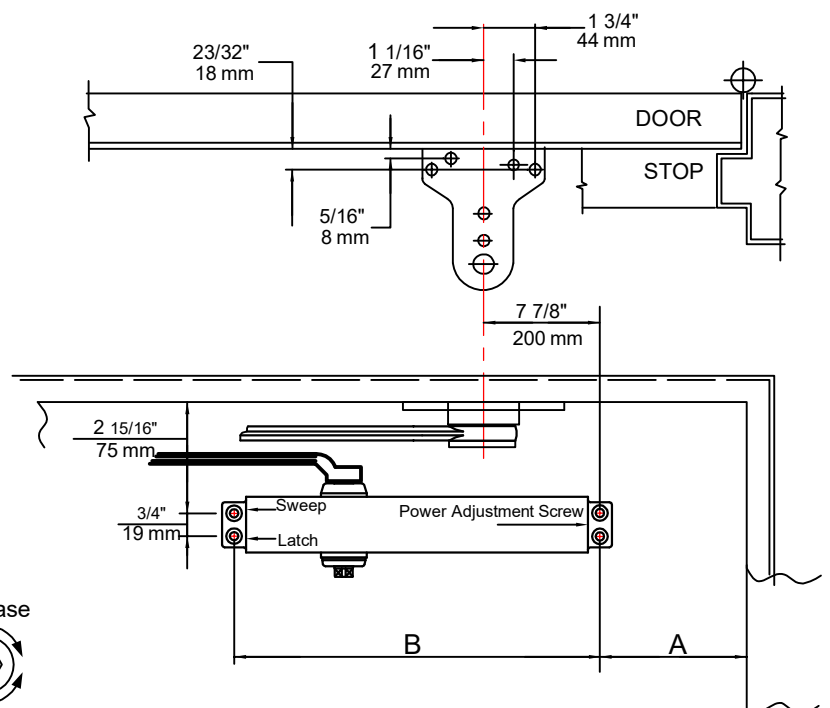
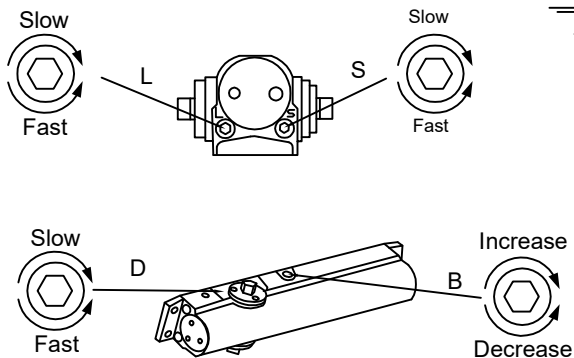

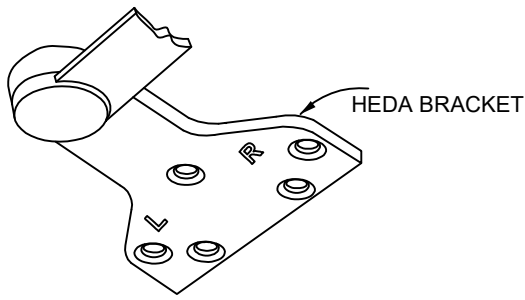

LEFT HAND DOOR SHOWN
(HEDA-LH)

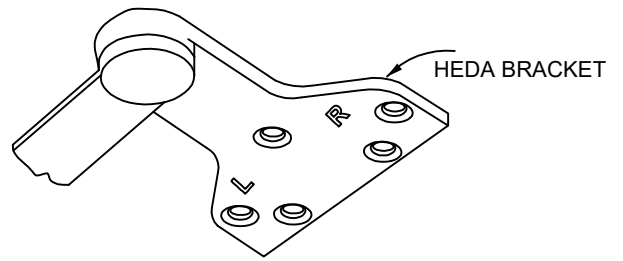

RIGHT HAND DOOR SHOWN
(HEDA-RH)

INSTALLATION DIMENSIONS ARE THE SAME
FOR BOTH LEFT HAND AND RIGHT HAND

CAUTION

IMPROPER INSTALLATION OR REGULATION
MAY RESULT IN PERSONAL INJURY OR
PROPERTY DAMAGE. FOLLOW ALL
INSTRUCTIONS CAREFULLY.

Illustration 1

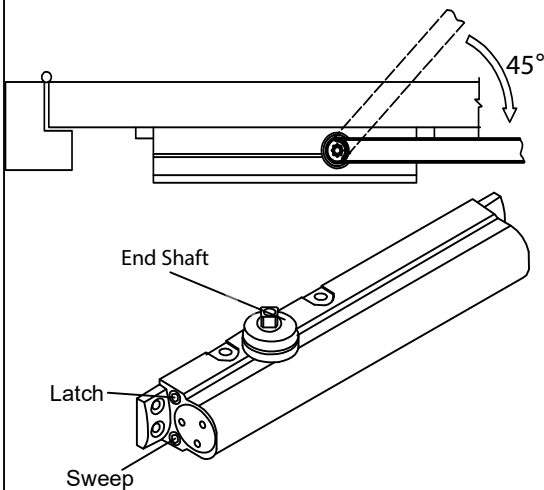

INSTALLATION:

1. Use dimensions shown above, mark 4 holes on door for door closer body and 4 holes on frame for HEDA bracket. Drill holes as required.
2. Mount closer on door using screws provided, Latch and Sweep Speed Adjusting valves must be positioned away from hinge side.
3. Mount HEDA bracket on door frame. Please choose the correct hand door for installing, RH- right hand door hold open and LH- left hand door hold open.
4. Use a wrench or extra arm to turn the bottom end shaft ~45° and put the main arm on the upper end shaft. Make sure the main arm is parallel with the door- See Illustration 1.
5. Adjust Sweep and Latch Speeds- normal closing time from 90° open position is 5 to 7 seconds evenly divided between Sweep and Latch Speeds. Adjust the SWEEP speed first, then adjust the LATCH speed.
6. Loosen the hold open nut with wrench and open the door to about 5 degrees less than the desired hold open position. Use wrench to securely tighten nut on the hold open arm- See Illustration 2.
7. Put on the cover and secure with screws provided- See Illustration 3.

Illustration 2

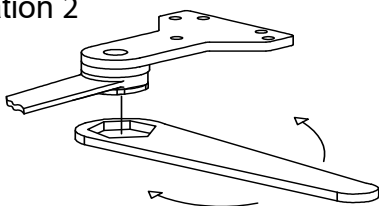

Illustration 3

